

Single Lid Parts List
Hydraulic Schematic and Parts List

Attention Dealers:

Please give this owners manual to the customer when the product is delivered.

• Indianapolis, IN • Omaha, NE • Streetsboro, OH



Parts List Directory

Item	Page
Lid 2 Overview	3
Front Mounting Brackets	4
Bed Mounting Hardware	5
Actuator Assembly & Front Arm Assembly DS	6
Actuator Assembly & Front Arm Assembly PS	7
Center Arm Assembly	8
Rear Arm Assembly DS	9
Rear Arm Assembly DS	10
Torque Tubes	11
Hydraulic Housing	12
Hydraulic Schematic - Stand Alone	13
Hydraulic Schematic & Parts List – Walking Floor	14
Hydraulic Cylinder & Counterbalance Valve Assembly	15
Spool Valve Assembly	16
Trailer Front Bulkhead & Priority Flow Divider	17
Hydraulic Parts List - Walking Floor	18

Lid 2 Overview

Parts List

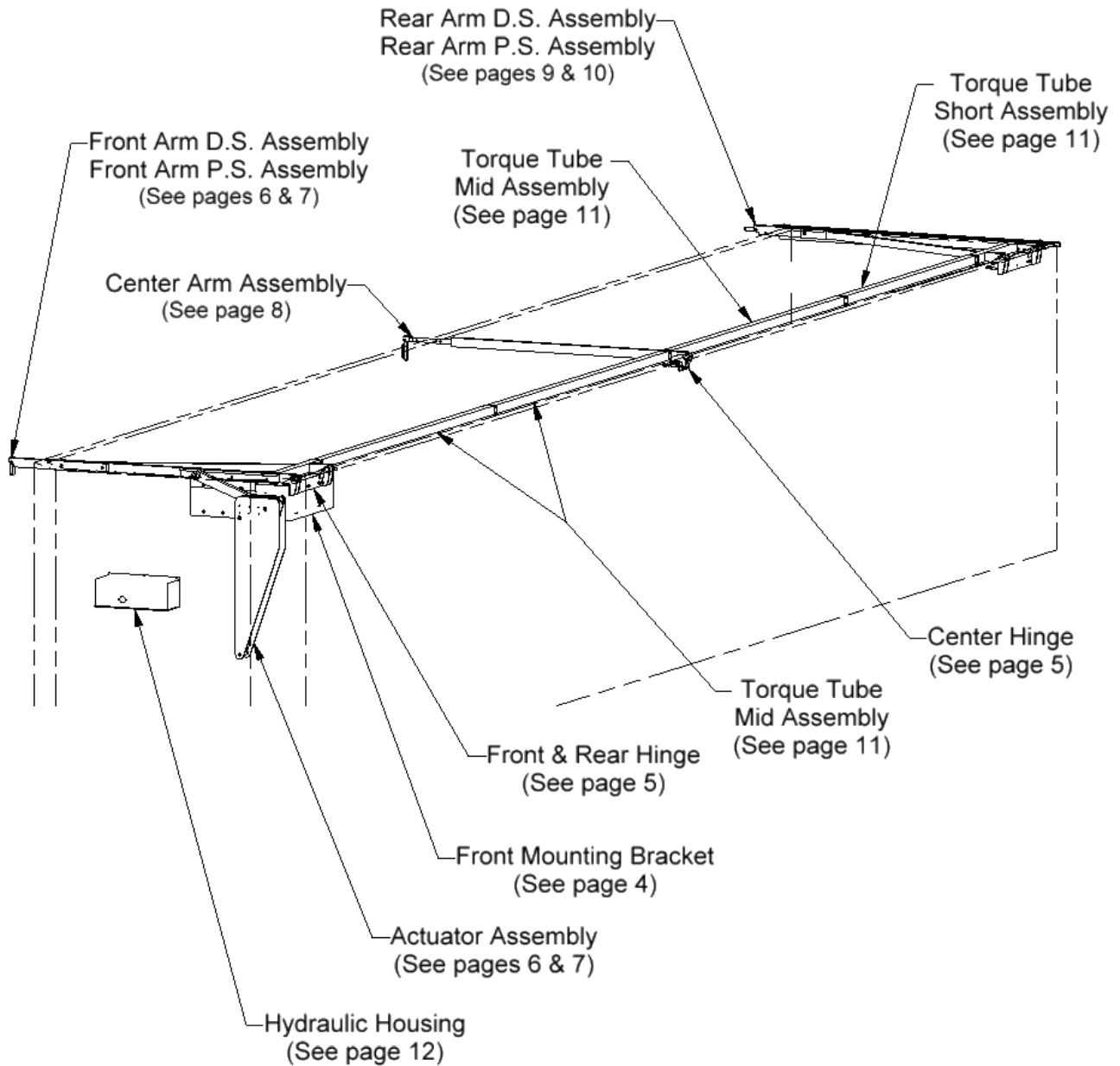

Important Notice to Customers:

This parts manual explains how to order replacement parts for you Lid 2. Be sure to read this page before placing an order with your Aero Sales Representative.

How to Order:

Attention Customers:

Front Mounting Brackets

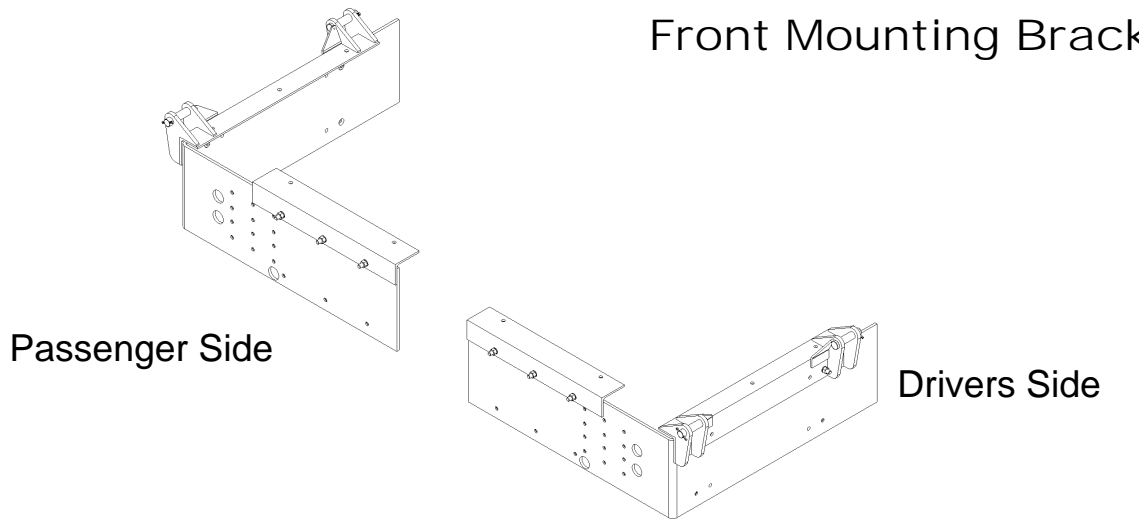

Passenger Side

Drivers Side

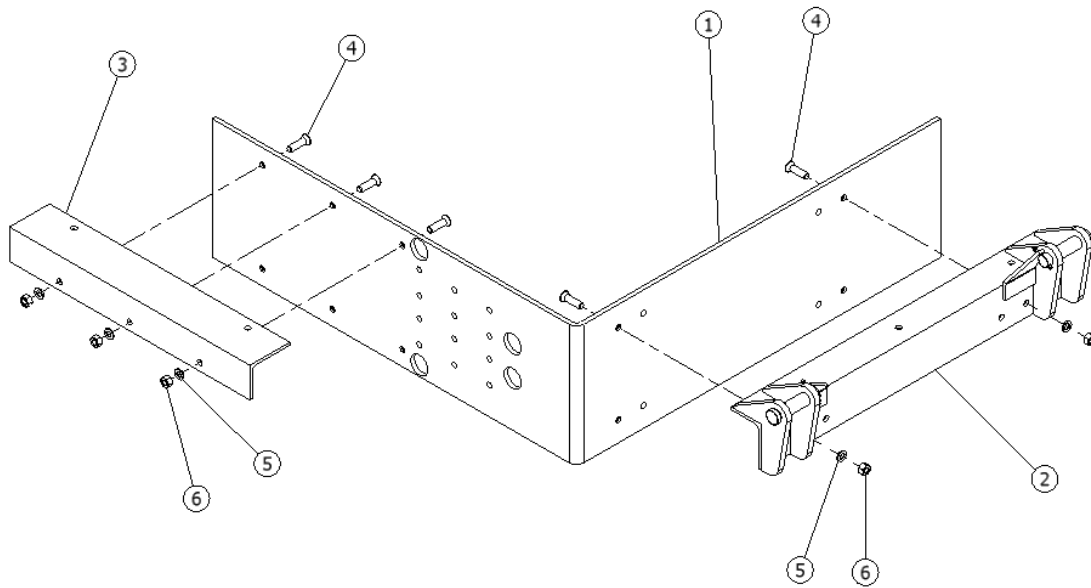

Index	Part No.	Description	Qty
1	1161-860474	Mounting Plate	1
2	1161-960527	Front & Rear Hinge Weldment	1
3	1161-860472	Front Mounting Angle	1
4	0825-660852	1/2-13 X 1 3/4" FHSCS	5
5	0820-680810	1/2 Flat Washer	5
6	0815-660855	1/2-13 Nylock Hex Nut	5

Front, Center, and Rear Hinges

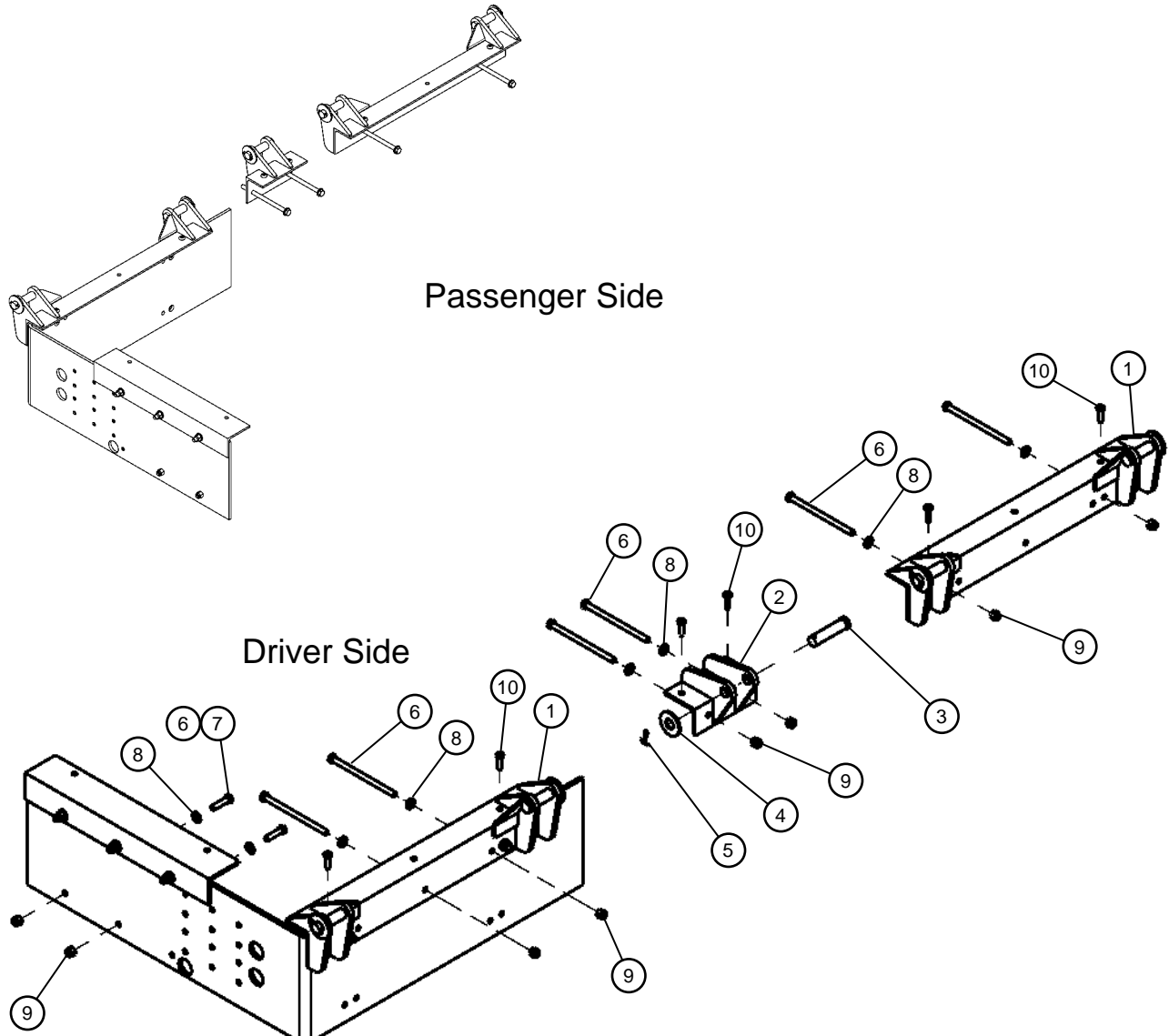

Passenger Side

Driver Side

Front Mounting Brackets
See Page 4

Index	Part No.	Description	Qty
1	1161-960527	Front & Rear Hinge Weldment	2
2	1161-960526	Center Hinge Weldment	1
3	0835-619620	Clevis Pin 1" x 4"	5
4	0820-618211	1" Flat Washer USS Zinc	5
5	0835-691624	Cotter Pin 3/16 x 1 1/2"	5

Index	Part No.	Description	Qty
6	0810-670853	1/2-13 x 8" Hex Bolt GR8	8
7	0825-670814	1/2-13 x 2" Hex Bolt GR8	2
8	0820-680810	1/2 Flat Washer	16
9	0815-660855	1/2-13 Nylock Hex Nut	8
10	0825-350621	3/8-16 x 1 1/2 Type F Torx	6

LID 2

Actuator Assembly & Front Arm Assembly

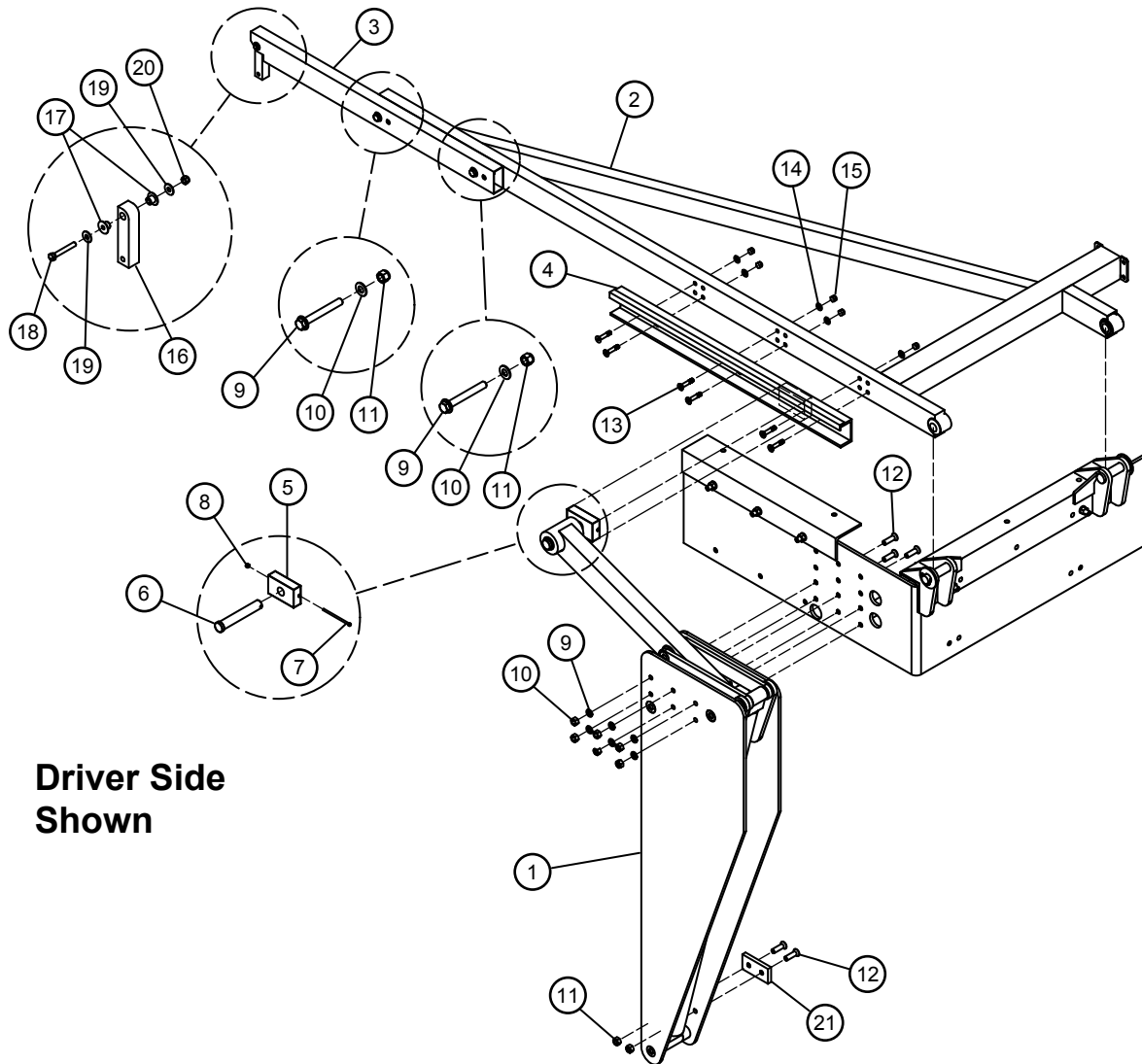

Driver Side
Shown

Index	Part No.	Description	Qty
1	1161-960424	Actuator Assembly	1
2	1161-960427	Front Arm Weldment	1
3	1161-860456	Arm Extension	1
4	1161-960423	Channel Weldment	1
5	1161-860442	Slide Block	1
6	0835-619621	Clevis Pin 1" x 6"	1
7	0825-650520	10-24 x 4" SHCS	1
8	0815-660932	10-24 Nylock Hex Nut	1
9	0810-650136	1/2-13 x 4" GR5	2
10	0820-680810	1/2 Flat Washer	10
11	0815-660855	1/2-13 Nylock Hex Nut	10

Index	Part No.	Description	Qty
12	0825-660852	1/2-13 x 1 3/4" FHSCS	8
13	0810-650833	3/8-16 x 2 1/2" FHSCS GR8	6
14	0820-680620	3/8 Flat Washer	6
15	0815-660660	3/8-16 Nylock Hex Nut	6
16	1161-860457	Tarp Mount	1
17	0845-691232	Bronze Bushing	2
18	0810-670445	5/16-18 x 2 1/4" Hex Bolt GR5	1
19	0820-680510	5/16-18 Flat Washer	2
20	0815-660550	5/16-18 Nylock Hex Nut	1
21	1161-860535	Bump Block	1

Actuator Assembly & Front Arm Assembly

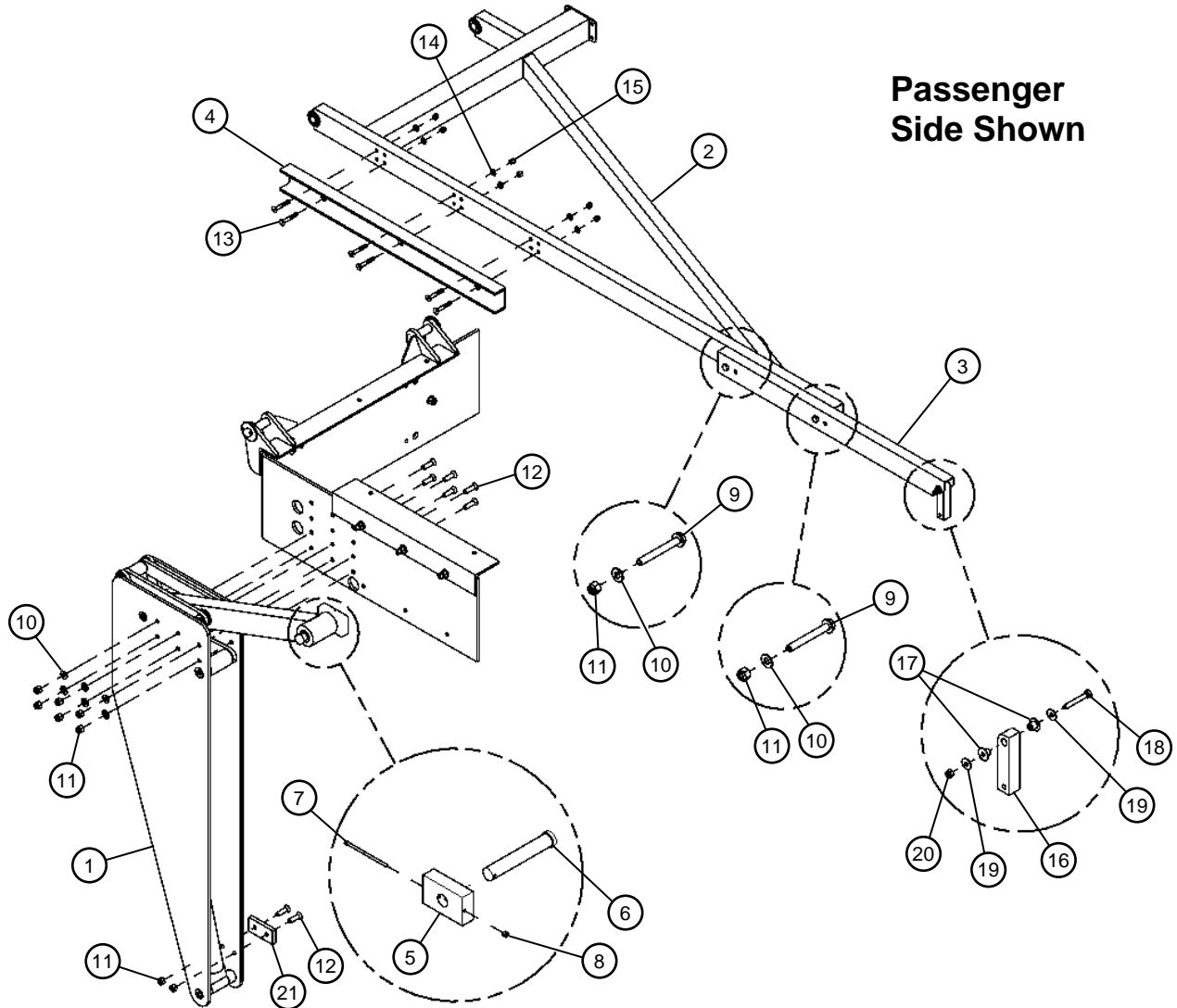

Index	Part No.	Description	Qty
1	1161-960424	Actuator Assembly	1
2	1161-960528	Front Arm Assembly	1
3	1161-860456	Arm Extension	1
4	1161-960423	Channel Weldment	1
5	1161-860442	Slide Block	1
6	0835-619621	Clevis Pin 1" x 6"	1
7	0825-650520	10-24 x 4" SHCS	1
8	0815-660932	10-24 Nylock Hex Nut	1
9	0810-650136	1/2-13 x 4" Hex Bolt GR5	2
10	0820-680810	1/2 Flat Washer	10
11	0815-660855	1/2-13 Hex Nut Nylock	10
12	0825-660852	1/2-13 x 1 3/4" FHSCS	8
13	0810-650833	3/8-16 x 2 1/2" FHSCS GR8	6
14	0820-680620	3/8 Flat Washer	6
15	0815-660660	3/8-16 Hex Nut Nylock	6
16	1161-860457	Tarp Mount	1
17	0845-691232	Bronze Bushing	2
18	0810-670445	5/16-18 x 2 1/4" Hex Bolt GR5	1
19	0820-680510	5/16 Flat Washer	2
20	0815-660550	5/16-18 Hex Nut Nylock	1
21	1161-860535	Bump Block	1

Center Arm Assembly

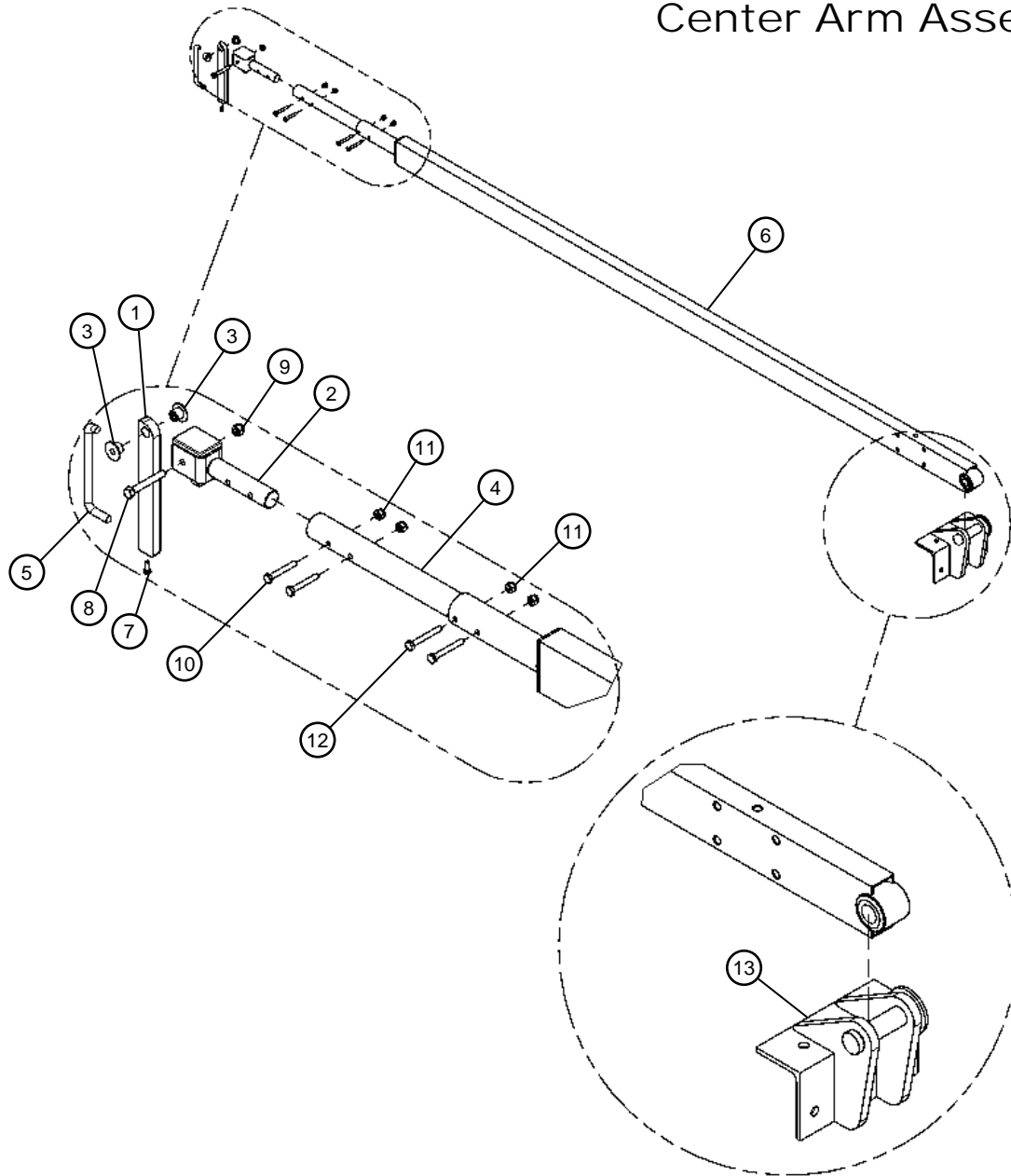

Index	Part No.	Description	Qty
1	1161-860489	Arm - Center Swing	1
2	1161-860488	Yoke Block Center	1
3	0845-691232	Bronze Bushing	2
4	1161-860531	Tube - Center Support - Short	1
5	1161-860490	Center Arm Rod	1
6	1161-960536	Mid Hinge Arm Assembly	1
7	0810-650550	10-32 x 1/2" Hex Bolt	1

Index	Part No.	Description	Qty
8	0810-670445	5/16-18 x 2 1/4" Hex Bolt GR5	1
9	0815-660550	5/16-18 Hex Nut Nylock	1
10	0810-650452	1/4-20 x 1 3/4" Hex Bolt GR8	2
11	0815-660451	1/4-20 Hex Nut Nylock	4
12	0810-650473	1/4-20 x 2" Hex Bolt	2
13	1161-960526	Center Hinge Weldment	1

LID 2

Rear Arm Assembly Parts List

Driver Side Shown

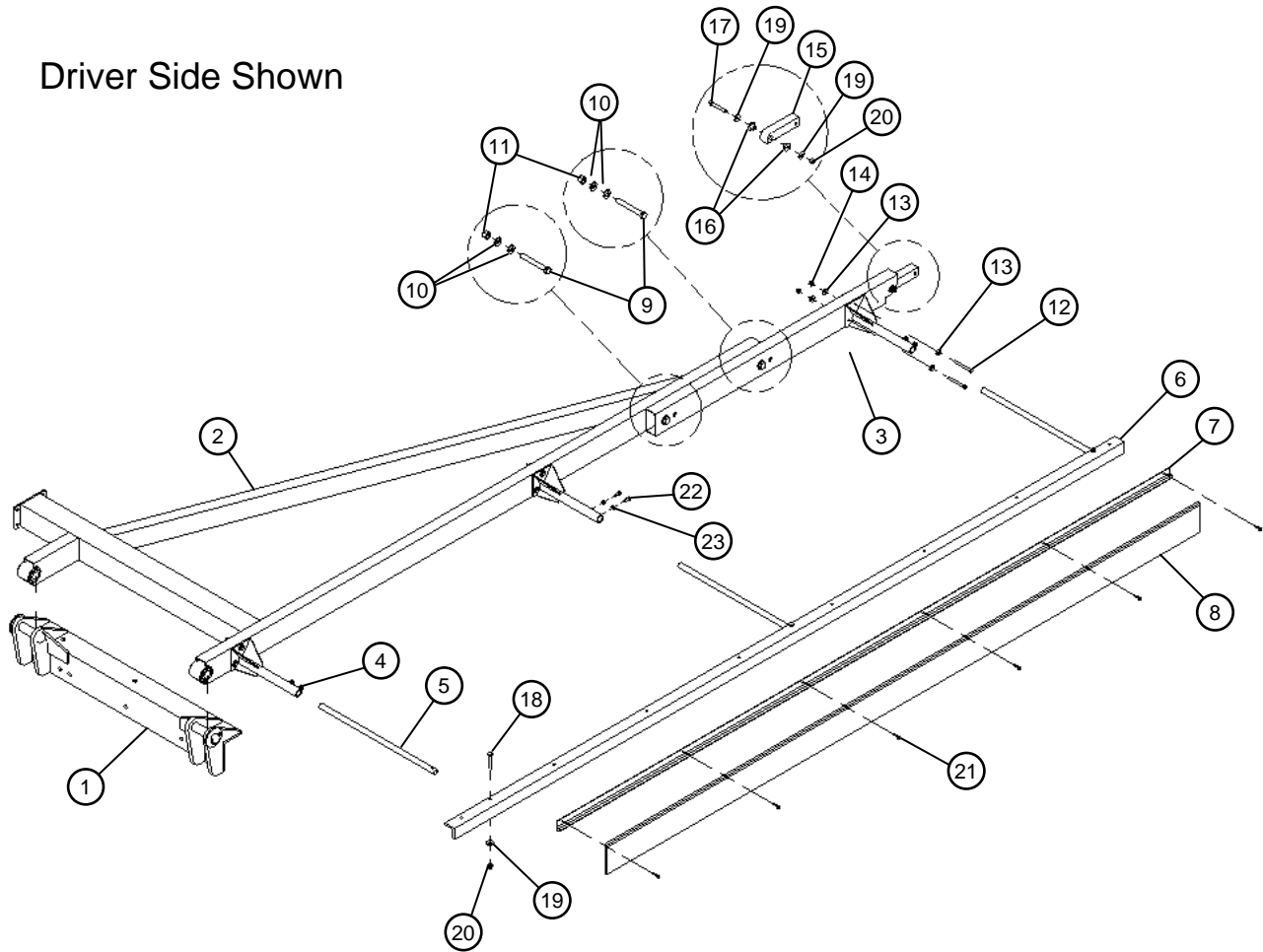

Index	Part No.	Description	Qty	Index	Part No.	Description	Qty
1	1161-960527	Front & Rear Hinge Weldment	1	13	0820-680410	1/4 Flat Washer	18
2	1161-960428	Front/Rear Arm Weldment	1	14	0815-660451	1/4-20 Nylock Hex Nut	9
3	1161-860456	Arm Extension	1	15	1161-860457	Tarp Mount	1
4	1161-960539	Tube Mount Weldment	3	16	0845-691232	Bronze Bushing	2
5	1161-860492	Extension Tube-Rear Arm	3	17	0810-650105	5/16-18 x 2 1/4" Hex Bolt GR5	1
6	1161-860479	Brush Holder Mounting Bar	1	18	0810-650102	5/16-18 x 2" Hex Bolt GR5	3
7	1161-960517	Brush Holder	1	19	0820-680510	5/16 Flat Washer	5
8	1161-960516	4" Nylon Brush	1	20	0815-660550	5/16-18 Nylock Hex Nut	4
9	0810-650835	1/2-13 x 4" Hex Bolt GR5	2	21	0825-670365	#12 x 1 Hex Washer TEK	6
10	0820-680810	1/2 Flat Washer	4	22	0810-650498	1/4-20 x 1/2" Hex Bolt GR5	6
11	0815-660855	1/2-13 Nylock Hex Nut	2	23	0815-660668	1/4-20 Jam Nut	6
12	0810-650435	1/4-20 x 2 1/2" Hex Bolt GR5	9				

Rear Arm Assembly Parts List

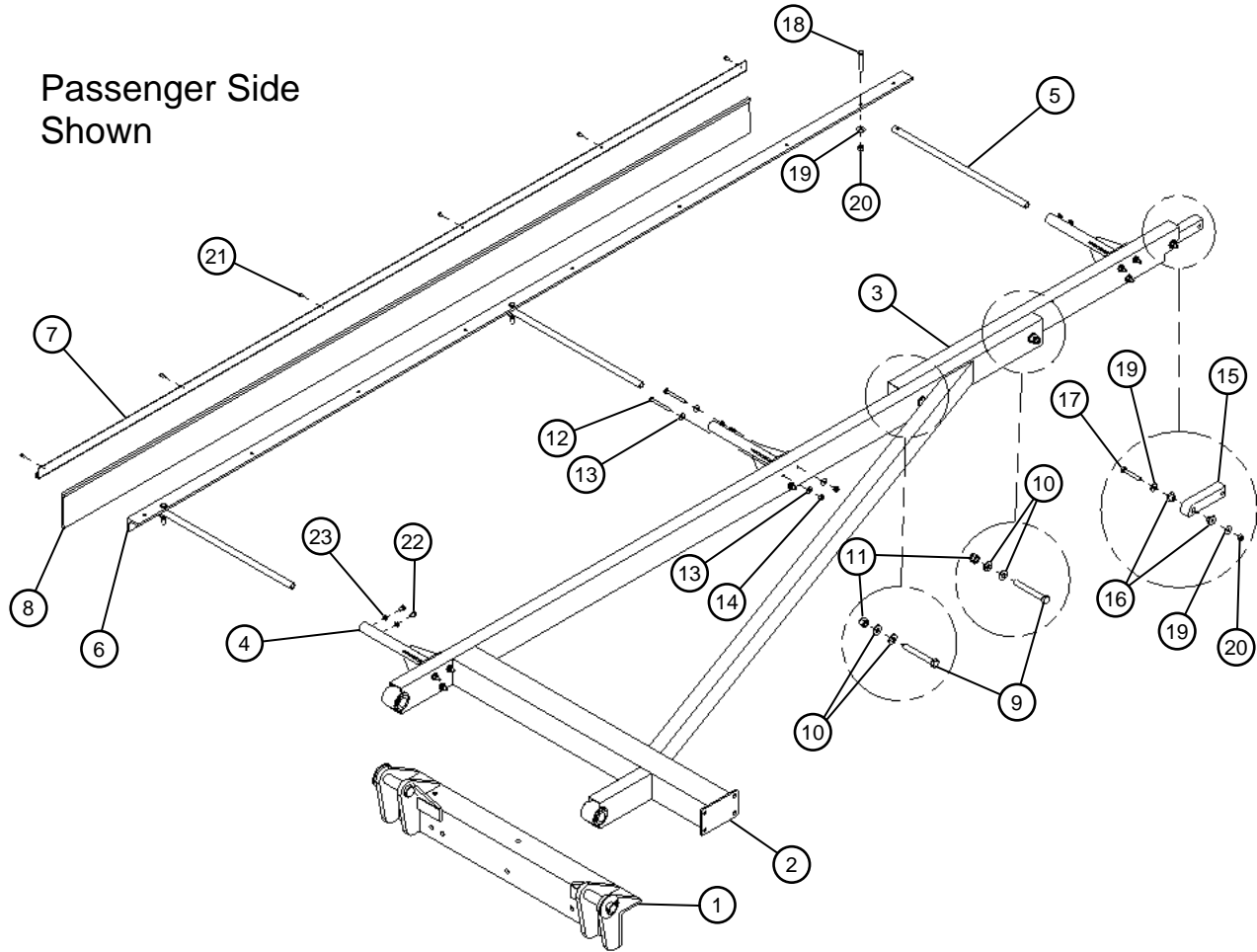

Index	Part No.	Description	Qty	Index	Part No.	Description	Qty
1	1161-960527	Front & Rear Hinge Weldment	1	13	0820-680410	1/4 Flat Washer	18
2	1161-960428	Front/Rear Arm Weldment	1	14	0815-660451	1/4-20 Nylock Hex Nut	9
3	1161-860456	Arm Extension	1	15	1161-860457	Tarp Mount	1
4	1161-960539	Tube Mount Weldment	3	16	0845-691232	Bronze Bushing	2
5	1161-860492	Extension Tube-Rear Arm	3	17	0810-650105	5/16-18 x 2 1/4" Hex Bolt GR5	1
6	1161-860479	Brush Holder Mounting Bar	1	18	0810-650102	5/16-18 x 2" Hex Bolt GR5	3
7	1161-960517	Brush Holder	1	19	0820-680510	5/16 Flat Washer	5
8	1161-960516	4" Nylon Brush	1	20	0815-660550	5/16-18 Nylock Hex Nut	4
9	0810-650835	1/2-13 x 4" Hex Bolt GR5	2	21	0825-670365	#12 x 1 Hex Washer TEK	6
10	0820-680810	1/2 Flat Washer	4	22	0810-650498	1/4-20 x 1/2" Hex Bolt GR5	6
11	0815-660855	1/2-13 Nylock Hex Nut	2	23	0815-660668	1/4-20 Jam Nut	6
12	0810-650435	1/4-20 x 2 1/2" Hex Bolt GR5	9				

LID 2

Torque Tubes

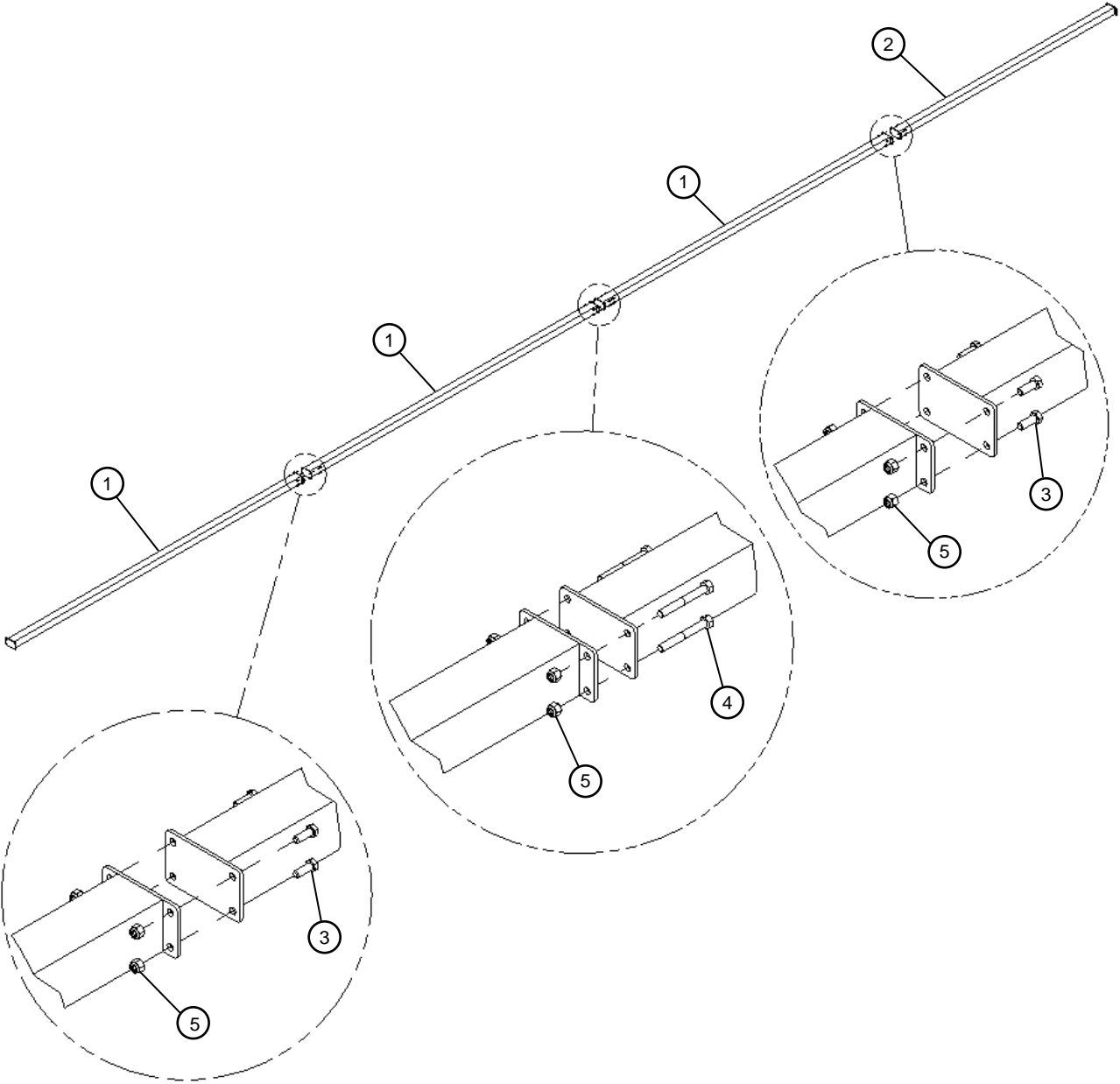

Index No. 2 is base on trailer length.

Torque Tube	
Part No.	Description
1161-960535	Torque Tube Short 48'
1161-960534	Torque Tube Short 53'

Index	Part No.	Description	Qty
1	1161-960530	Torque Tube - Mid Assembly	3
2	See Chart	Torque Tube	1
3	0810-670650	3/8-16 x 1" Hex Bolt	16
4	0810-650618	3/8-16 x 3" Hex Bolt	4
5	0815-660660	3/8-16 Nylock Hex Nut	20

LID 2

Hydraulic Housing Parts List

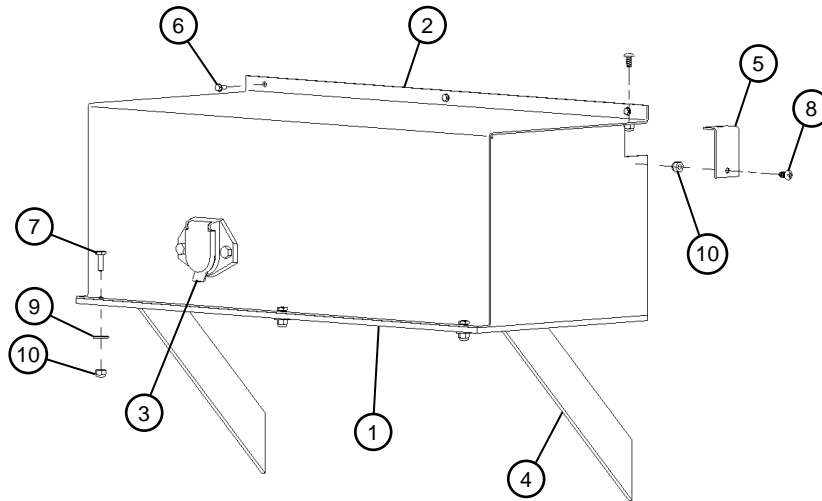

Index	Part No.	Description	Qty
1	1161-860494	Hydraulic Mounting Plate	1
2	1161-960429	Hydraulic Enclosure	1
3	0755-626460	Plug Quick Disconnect Assy (Includes Male & Female)	1
4	1161-860548	Angle Housing Support	2
5	1161-860540	Hose Opening Cover	1

Parts included in Hydraulic Enclosure

Index	Description	Qty
5	Hose Opening Cover	1
6	#12 x 1 Hex Washer TEK	3
7	1/4-20 x 3/4" Hex Bolt	3
8	1/4-20 x 1/2 Phillips Pan Head	2
9	1/4 Flat Washer	3
10	1/4-20 Nylock Hex Nut	5

Walking Floor Schematic

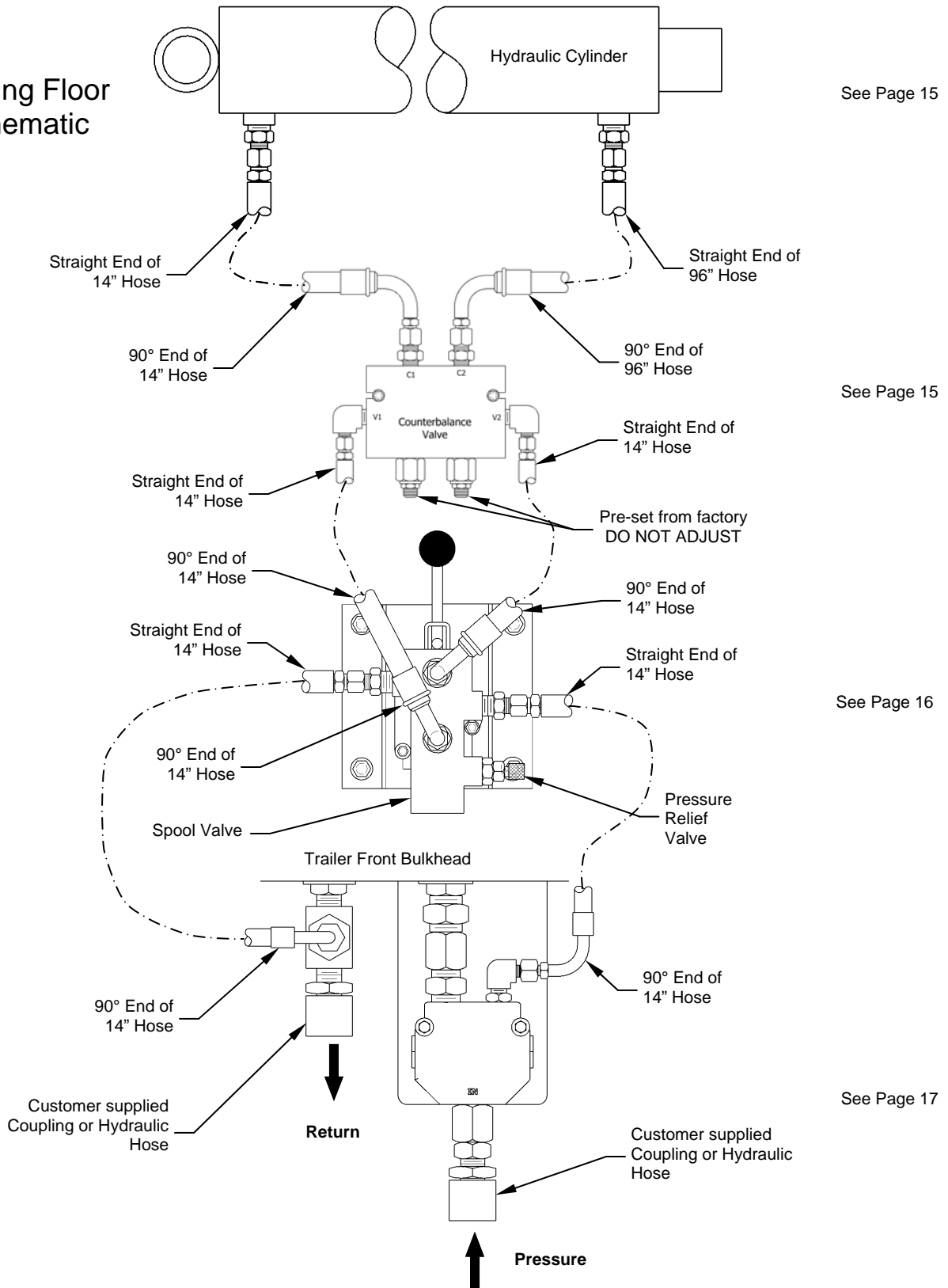

Hydraulic Cylinder

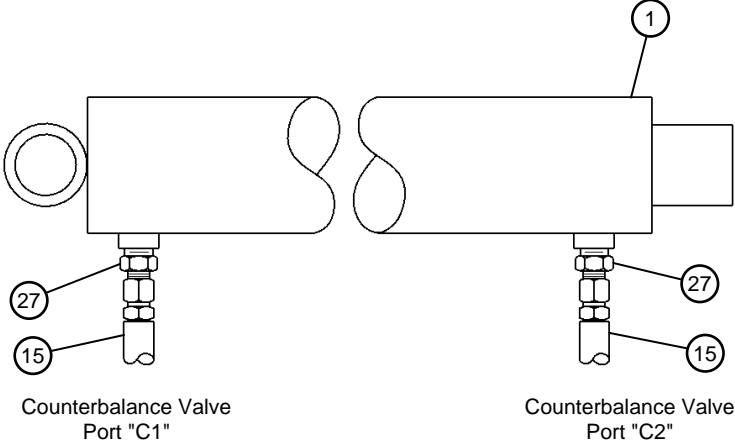

Counterbalance Valve Assembly (Front View)

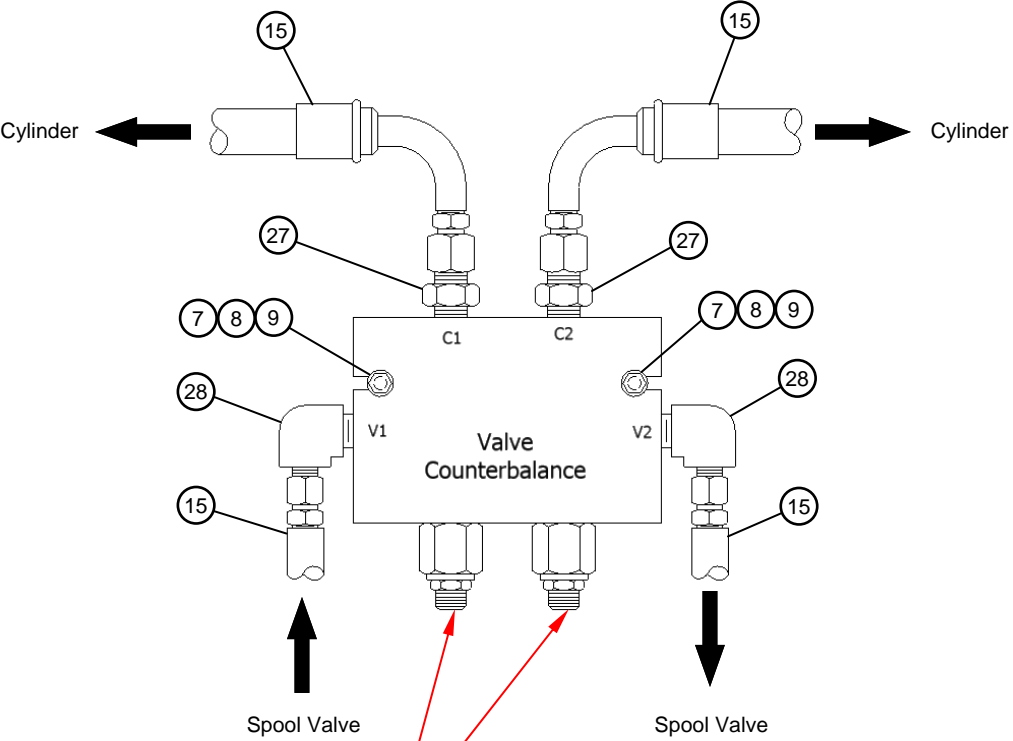

**These Adjustment Screws
come pre-set from the factory
for this application, and do
not require adjustment**

Spool Valve Assembly (Front View)

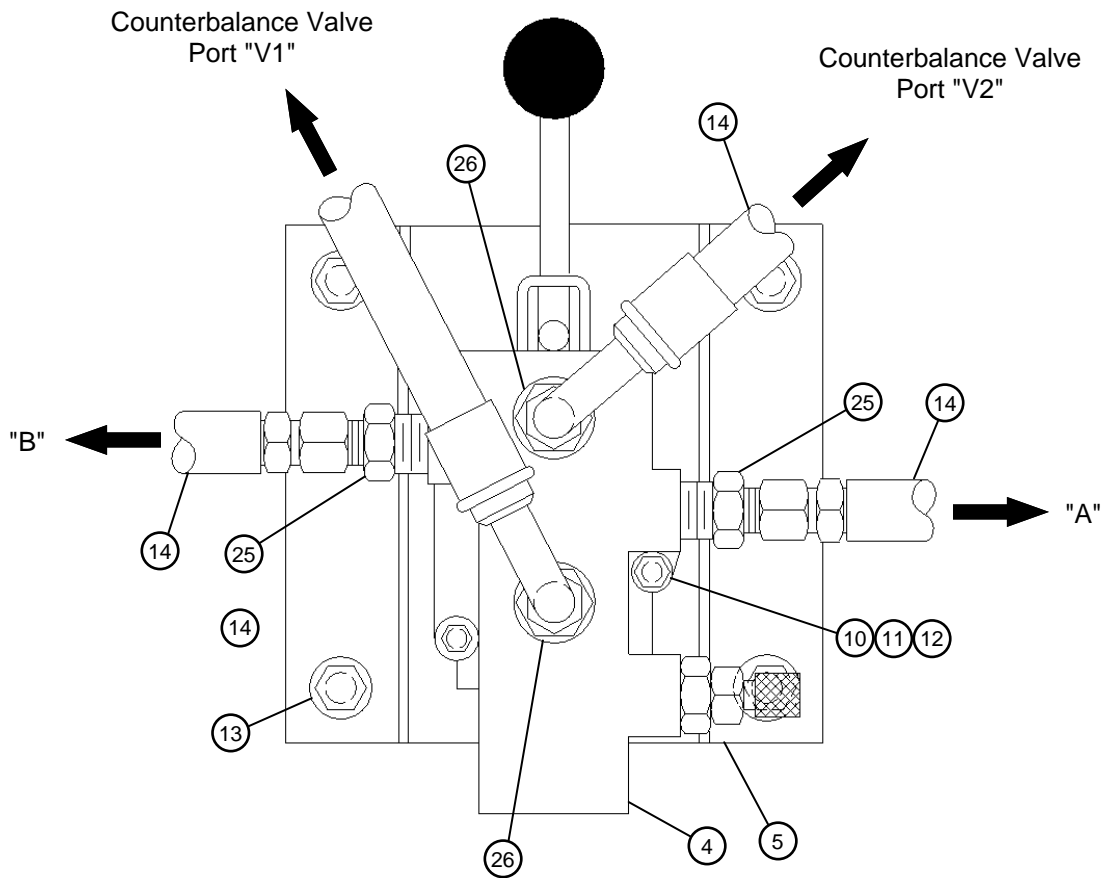

Trailer Front Bulkhead

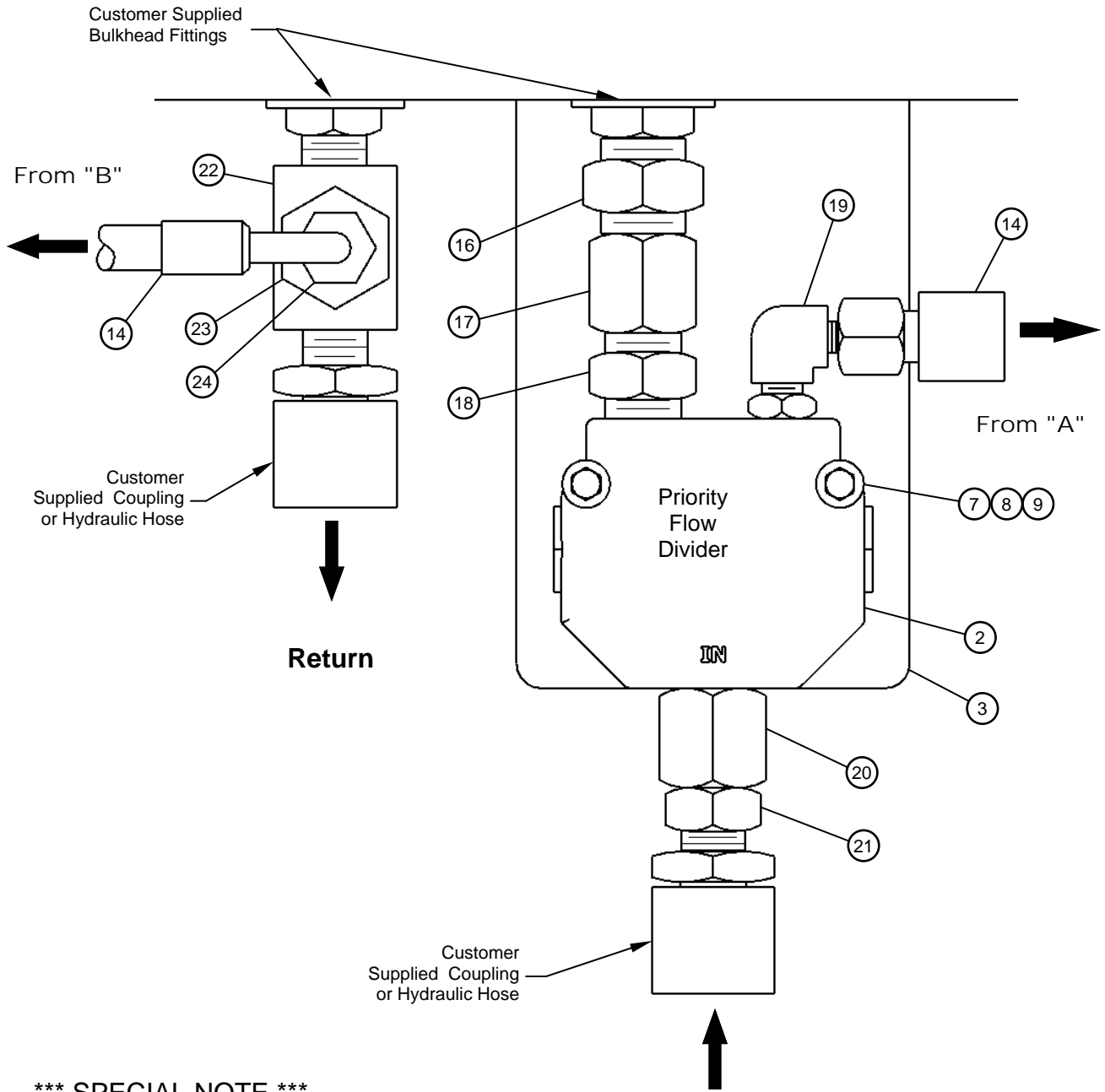

*** SPECIAL NOTE ***

Hydraulic components furnished with this Kit are setup for 1" Female NPT connections into the trailer. If the trailer is equipped with connections other than stated, additional hydraulic fittings will be required, and are not supplied with this Kit. Consult trailer manufacture if you have any concerns with using the hydraulics on the trailer. Longer hydraulic hoses may be required for special applications.

Walking Floor Schematic

Index	Part No.	Description	Qty
1	1161-860218	Hydraulic Cylinder	1
2	0790-100050	Priority Flow Divider	1
3	1161-860300	Flow Divider Mounting Plate	1
4	0790-100006	Spool Valve	1
5	1161-860301	Spool Valve Mounting Bracket	1
6	0790-100014	Counterbalance Valve	1
7	0810-670454	1/4-20 X 2 1/2" Hex Bolt GR2 Zinc	4
8	0820-680410	1/4" Flat Washer Zinc	8
9	0815-660451	1/4-20 Nylock Hex Nut	4
10	0810-650102	5/16-16 X 2" Hex Bolt	3
11	0820-680510	5/16 Flat Washer	10
12	0815-660-510	5/16-18 Hex Nut	3
13	0825-670504	5/16 X 1" Type F Self Tapping	7
14	0790-200000	Hyd. Hose M6 X 14" O.A.L. - M6 FJIC Straight x M6 FJIC Elbow	4
15	0790-200003	Hyd. Hose M6 X 96" O.A.L. - M6 FJIC Straight x M6 FJIC Elbow	1
16	0790-100010	Straight Adapter 1" MNPT X 1" MNPT	1
17	0790-100057	Coupling 3/4" FNPT X 1" FNPT	1
18	0790-100051	Straight Adapter M12 MORB x 3/4" MPNT	1
19	0790-100052	Male 90° Elbow M6 MJIC x M8 MORB	1
20	0790-100056	Straight Adapter M16 FORB x M12 MORB	1
21	0790-100055	Straight Adapter M16 MORB x 1" FNPT	1
22	0790-100004	Male Run Tee 1" NPT	1
23	0790-100054	Straight Adapter 3/4" FNPT x 1" MNPT	
24	0790-100053	Straight Adapter 3/4" MNTP X M6 MJIC	1
25	0790-100007	Straight Adapter M8 SAE X M6 MJIC	2
26	0790-100008	Straight Adapter M10 SAE X M6 MJIC	2
27	0790-100009	Straight Adapter M6 SAE X M6 MJIC	4
28	0790-100022	90° Elbow M6 SAE X M6 MJIC	2

Aero Industries, Inc.



Indianapolis, IN - 4243 Bradbury Avenue, Indianapolis, IN, 46241 - 800-535-9545 - FAX: 317-244-1311

Omaha, NE - I-80 & Highway 50 South, Omaha, NE, 68137 - 800-535-9545 - FAX: 402-895-5129

Streetsboro, OH - 8540 State Route 14, Streetsboro, OH, 44241 - 888-237-2262 - FAX: 330-626-3277

Aero Industries, Inc. 0930-868026 5/10/11 Rev. E